

JANUS CYLINDERS

DOUBLE AND SINGLE ACTING

Design

Based on a tie bar design, the standard range of cylinders offer durable construction with a high degree of corrosion resistance. The cylinders can be supplied as single or double acting with a maximum pressure of 160 bar and maximum speed of 0.3 m/sec.

The standard cylinder construction is 316 stainless steel with a high grade engineering polymer seal, Duplex stainless steel cylinders can be manufactured for seawater service. An additional ceramic coating can be applied for extreme operating environments and duty cycles. The Janus cylinder design is simple and robust ensuring a long service life with low maintenance; offering a most cost effective solution. TWHC can offer special cylinders to suit customer applications or specifications; please contact us with your specific requirements.

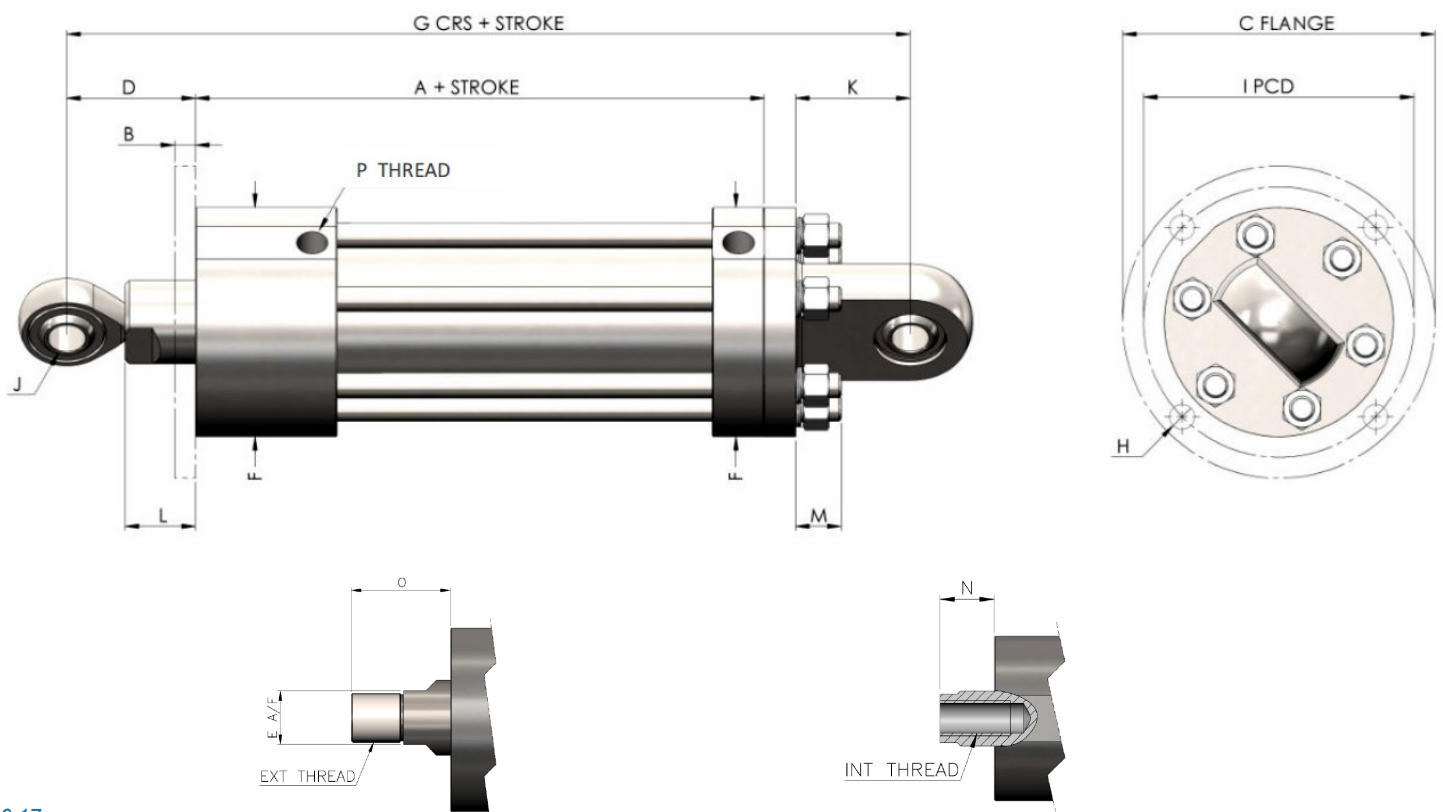

JANUS CYLNDERS

DOUBLE AND SINGLE ACTING

NOMINAL	BORE		32		40	50		64		80	100		125
	ROD		16	20	25	25	30	30	40	50	60	80	80
ROD INTERNAL THREAD (SIZE x PITCH x LENGTH)			M8 X 1.25 x 16	M12 x 1.75 x 30	M16 x 2 x 32	M18 x 1.5 x 45	M20 x 1.5 x 45	M18 x 1.5 x 45	M24 x 2 x 40	M36 x 3 x 72	M36 x 3 x 72	M36 x 2 x 72	M36 x 2 X 72
ROD EXTERNAL THREAD (SIZE x PITCH x LENGTH)			M12 x 1.75 x 25	M16 x 2 x25	M22 x 1.5 x 25	M22 x 1.5 x 25	M24 x 3 x 30	M24 x 3 x 35	M33 x 3.5 x 35	M36 x 3 x 36	M36 x 3 x 36	M36 x 3 x 36	M36 x 3 x 36
A			90	90	113	119.2	119.2	158.2	158.2	178	195	195	234
B FLANGE WIDTH			11	11	15	15	15	15	15	21.5	25	30	30
C Ø			85	85	112	130	130	160	160	196	230	230	325
D NO FLANGE			42.9	33.9	52.7	50	54.3	43.8	72.8	88.5	89.5	79.5	79
E A/F			13	17	22	22	27	25	36	42	55	75	75
F Ø			60	60	75	92	92	110	110	125	160	160	215
G CRS+STROKE			156.9	156.9	209.7	219.2	223.5	272	287	333	359.5	349.5	387
H Ø			8.5	8.5	10.5	10.5	10.5	11.5	11.5	13	16	16	22
I PCD			73.5	73.5	92	110	110	135	135	156	190	190	280
J Ø PLAIN			8	8	16	18	18	18	18	35	35	35	40
K			25	25	37	50	50	55	55	51.5	60	60	80
L PLAIN (WIDEST POINT)	ROD		15	21	22	20	20	29	29	36	40	40	40
	BODY		15	21	22	20	20	29	29	36	40	40	40
M STUD LENGTH			12.5	10.5	12	12	15.8	21.8	21.8	19	20.5	25.5	29
N WITHOUT FLANGE			16.9	16.9	24.7	22	26.3	15.8	30.8	35.5	36.5	26.5	9
O MALE WITHOUT FLANGE			30.9	30.9	34.7	47.3	52.3	65.8	65.8	71.5	72.5	62.5	45
P BSP P			1/4"	1/4"	1/4"	1/4"	1/4"	3/8"	3/8"	1/2"	1/2"	1/2"	1/2"
SPHERICAL BEARINGS	D NO FLANGE		42.9	33.9	52.7	50	54.3	43.8	72.8	88.5	89.5	79.5	79
	G CRS + STROKE		156.9	156.9	209.7	219.2	223.5	272	287	333	359.5	349.5	387
	J Ø		8	8	16	18	18	18	18	35	35	35	40
	K		25	25	37	50	50	55	55	51.5	60	60	80
	L (WIDES T)	ROD	12	12	21	21	23	23	23	43	43	43	49
BODY		12	12	21	23	23	25	25	43	43	43	49	

JANUS CYLINDERS

DOUBLE AND SINGLE ACTING

Assembly Ordering Codes:

BORE (mm)		MEDIUM		ACTION		ROD (mm)		ROD END		BODY MOUNTING		STROKE (mm)	
*		*		*		*		*		*		*	
032	Ø32	W	Tap Water	S	Single Acting	16	Ø16	M	Male Thread	B	Rear Flange	50 Min.	050
040	Ø40	S	Salt Water			20	Ø20	F	Female Thread	F	Front Flange		
050	Ø50	T	Tech. Water	D	Double Acting	25	Ø25	U	Plain Bearing	U	Plain Bearing	1500 Max.	1500
064	Ø64	O	Other			30	Ø30	R	Spherical Bearing	R	Spherical Bearing		
080	Ø80					40	Ø40						
100	Ø100					50	Ø50						
125	Ø125					60	Ø60						
						80	Ø80						



Example

Ø50 bore, Ø25 rod, 300 stroke, double acting, male threaded rod end & front flange mounted, to be used with tap water.

Ordering Code : **050 W D 25 M F 300**



Specials

- Extended sizes from table shown
- Double end
- Proximity sensors
- Linear transducers for positional feedback
- Special mounting for design integration